

ROBOTICS

GoFa™ CRB 15000

Go far with your new helping hand



Go faster. Go further than ever. GoFa's class-leading speed, safety, and ease of use will take your business to the next level.

Introducing GoFa

GoFa incorporates a range of features that allow it to be used safely, directly alongside human workers and without the need to design and build bulky barriers or fencing. GoFa can continuously share workspace with people, giving it maximum flexibility and efficiency. Robot and human cooperate on the same tasks, without jeopardizing productivity or safety.

Strong yet safe

Designed for handling payloads up to 14 kg*, GoFa has integrated torque sensors in each of its six joints offering superior power and force limiting performance. Together, these prevent the risk of injury by bringing GoFa to an immediate stop if it senses any contact with a human worker.

Built-in Force control for advanced applications

The force control option enables GoFa to adjust its motion based on measured force input without the need of any additional hardware thanks to our unique architecture. This capability allows the cobot to maintain a consistent force between itself and the objects it interacts with, while also

adjusting its path and speed. This feature is essential for applications such as polishing, sanding, deburring, testing, and assembly.

Easy set-up and operation

Set up and configuration is easy with intuitive, graphical Apps directly on the FlexPendant. You can move your robot using lead through in no time.

Faster performance for greater productivity

GoFa offers a maximum Tool Center Point (TCP) speed of up to 2,2 m/s,¹ faster than other cobots in its class. GoFa can perform more operations in a set period than competing robots.

Ultra Accuracy for high precision tasks

GoFa Ultra Accuracy feature ensures exceptional precision with path accuracy down to 0.03 mm and absolute position accuracy of 0.1 mm, perfect for high-stakes applications like gluing, sealing, laser welding, and precision cutting, delivering over 10 times greater path accuracy than other cobots.

* wrist down configuration



Key features:



Collaborative safety

- Superior power and force limiting performance through integrated torque sensors,
- Safe design of robot, rounded geometry, no pinch/trap points,
- Safety certified Category 3, PL d.



Easy to use

- Enhanced interaction with arm side interface,
- Lead-through anywhere on the robot,
- Wizard easy programming,
- SafeMove configurator App on the FlexPendant.



Accuracy:

- With path accuracy down to 0.03mm, GoFa delivers over 10 times greater accuracy than other cobots*
- Absolute position accuracy of 0.1 mm maintains tight tolerances*
- Offline programming with RobotStudio® achieves up to 99% match between simulation and reality, reducing the need for adjustments and ensuring efficient deployment*
- * Available with GoFa Ultra Accuracy option



Productivity

- With a TCP speed of up to 2,2 m/s², GoFa is faster than other cobots in its class,
- Up to 1,62 m reach, 14% longer than other comparable robots,
- Up to 20% energy savings,
- Best-in-class repeatability of 0,02 mm on the market.



Applications

- Machine tending,
- Welding,
- Palletizing,
- Assembly,
- Screwdriving,
- And many more...

Specification			
	GoFa 5	GoFa 12	GoFa 10
Reach (mm)	950 (wrist) 1050 (flange)	1270 (wrist) 1370 (flange)	1520 (wrist) 1620 (flange)
Payload (kg)	5	up to 14kg*	up to 12kg*
Arm load (kg)	1 (mounted on axis 4)	1 (mounted on axis 2, 3, or 4)	1 (mounted on axis 2, 3 or 4)
Number of axes	6	6	6
Protection	IP54	IP67	IP67
Cleanroom class	ISO cleanroom 4	ISO cleanroom 4	ISO cleanroom 4
Mounting	Any angle, including table mounting, wall mounting, and ceiling mounting		
Controller	OmniCore C30		
Controller power needed to run the GoFa arm	100 – 230 VAC 50 – 60 Hz		
Customer power supply	M8, 3 pins connector, 24V/3A		
Customer signals	M8, 4 pins connector, CAT 5 cable, up to 4 digital signals available for digital IOs, Analog IOs, Fieldbuses and Ethernet based protocols		
Tool flange	Standard ISO 9409-1-50		
Ambient Temperature	5°C to 40°C	5°C to 40°C	5°C to 45°C
Humidity	<75% relative humidity For limited period (<1 month): <95% relative humidity	<75% relative humidity For limited period (<1 month): <95% relative humidity	<75% relative humidity For limited period (<1 month): <95% relative humidity
Average Power Consumption	250W	250W	250W
Additional Options	Force control, integrated vision, conveyor tracking	Force control, integrated vision, conveyor tracking	Force control, integrated vision, conveyor tracking
Functional safety	SafeMove Collaborative included all safety functions certified to Category 3, PL d. It includes upto 16 safety zones		

Certifications

SGS Functional safety ISO 10218-1:2011 and the applicable portions of ISO/TS 15066, ISO 13849-1:2015, IEC 60204-1:2016
The product is compliant with ISO 10218-1:2011

Additional Certifications (Standards) UL1740 (for USA), CSA Z434 (for Canada)

* wrist down configuration

OmniCore™

	GoFa 5	GoFa 12	GoFa 10
Physical Controller Dimensions	C30 449x443x170 (WxDxH) mm Weight 24kg		
Available Connections	Expandable Digital I/Os, Analog I/Os, Safety I/Os		
Power requirements	100 - 230 VAC 50 - 60 Hz single phase		
Available Communication Protocol	TCP/UDP IP, RTU, Fieldbuses: PROFINET Controller, PROFINET Device, PROFInergy, PROFIsafe Controller PROFIsafe Device, EtherNet/IP Scanner, EtherNet/IP Adapter, CC-Link IE FB Master, CC-Link IE FB Device DeviceNet c/d		
Mounting Options	Standing, Rack mount, Vertical mount, Desktop Design		
IP Level	IP20		

FlexPendant

	GoFa 5	GoFa 12	GoFa 10
Screen	8" color touch screen		
Resolution	1024x768		
Protection	IP54		
Available Cable Length	3m, 10m + extensions		
Additional Features	3D Joystick Adaptable for left-handed users		

Performance			
	GoFa 5	GoFa 12	GoFa 10
Max TCP Velocity	2,2 m/s	2 m/s	2 m/s
Max TCP acceleration (Controlled motion for nominal load)	36,9 m/s ²	27 m/s ²	28 m/s ²
Max TCP acceleration (e-stop for nominal load)	61,6 m/s ²	79 m/s ²	94 m/s ²
Pose repeatability	0.02 mm	0.02 mm	0.02 mm

Ultra Accuracy (Feature)			
	GoFa 5	GoFa 12	GoFa 10
Absolute Position Accuracy	0.1mm	0.1mm	0.1mm
Path Accuracy	Down to 0.03mm	Down to 0.03mm	Down to 0.03mm

Ultra Accuracy Test Performance (Error measurement)			
	GoFa 5	GoFa 12	GoFa 10
Average Error	0.04mm	0.04mm	0.04mm
Max Error	0.16mm	0.15mm	0.18mm

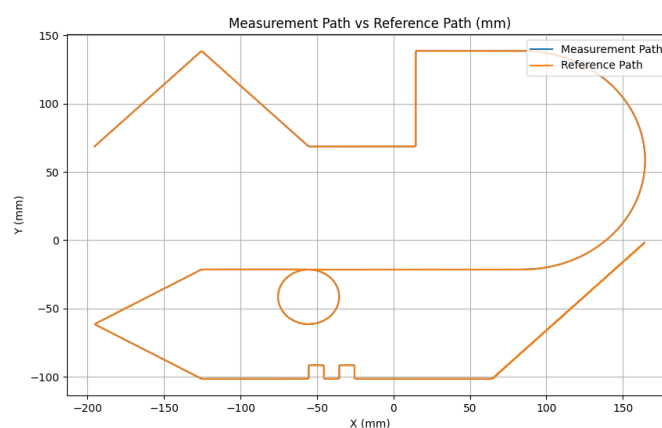

GoFa Ultra Accuracy Test: Reference Path vs. Measured Path

Physical						
	GoFa 5		GoFa 12		GoFa 10	
Dimensions robot base	165 x 165 mm		200 x 200 mm		200 x 200 mm	
Weight	28 kg		48 kg		51 kg	
Movement						
	GoFa 5		GoFa 12		GoFa 10	
Axis movement	Working range	Axis max. speed	Working range	Axis max. speed	Working range	Axis max. speed
Axis 1 rotation	-180° to 180°	125 °/s	-270° to 270°	120 °/s	-270° to 270°	120 °/s
Axis 2 arm	-180° to 180°	125 °/s	-180° to 180°	120 °/s	-180° to 180°	120 °/s
Axis 3 arm	-225° to 85°	140 °/s	-225° to 85°	125 °/s	-225° to 85°	125 °/s
Axis 4 wrist	-180° to 180°	200 °/s	-180° to 180°	200 °/s	-180° to 180°	200 °/s
Axis 5 bend	-180° to 180°	200 °/s	-180° to 180°	200 °/s	-180° to 180°	200 °/s
Axis 6 turn	-270° to 270°	200 °/s	-270° to 270°	200 °/s	-270° to 270°	200 °/s

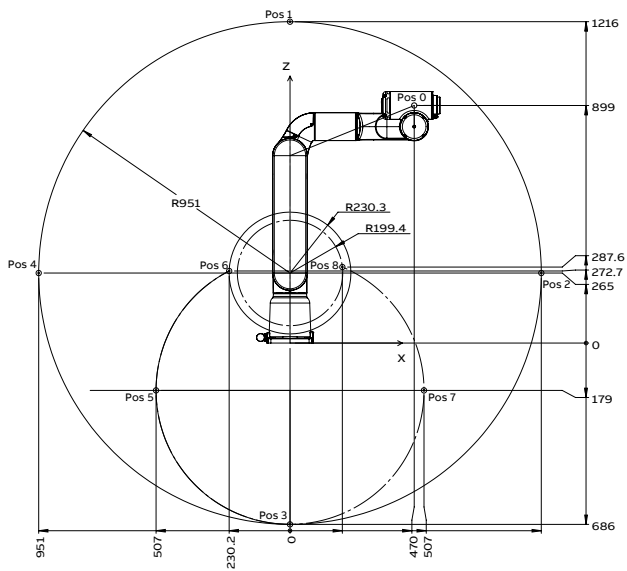

01 GoFa 5 Working range, Side view

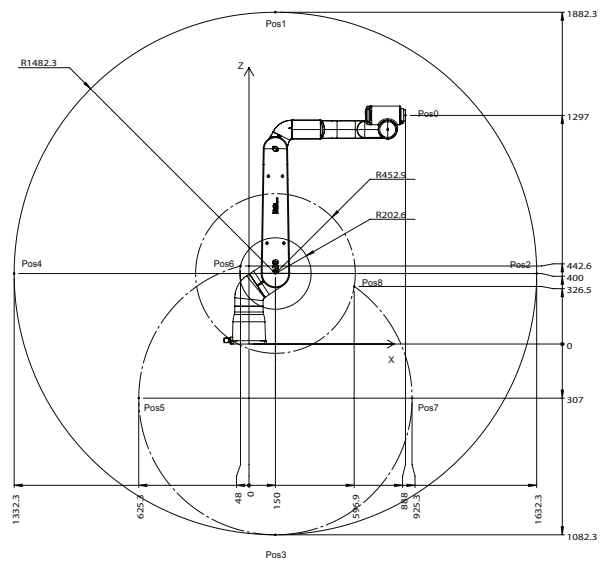

02 GoFa 10 Working range, Side view

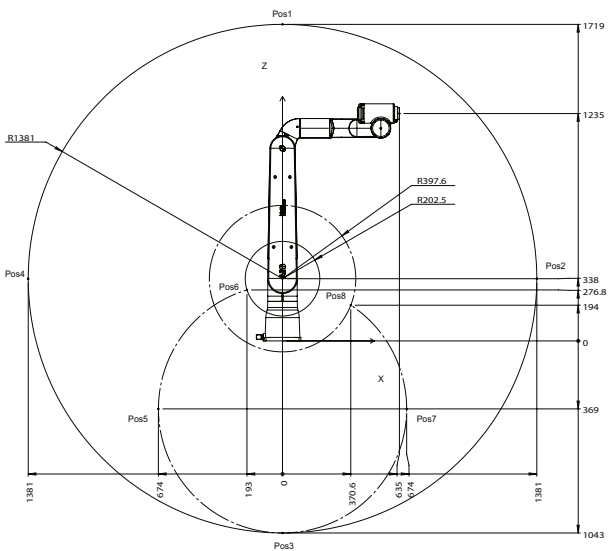

03 GoFa 12 Working range, Side view

We reserve the right to make technical changes or modify the contents of this document without prior notice. With regard to purchase orders, the agreed particulars shall prevail. ABB AG does not accept any responsibility whatsoever for potential errors or possible lack of information in this document.

We reserve all rights in this document and in the subject matter and illustrations contained therein. Any reproduction, disclosure to third parties or utilization of its contents – in whole or in parts – is forbidden without prior written consent of ABB AG. Copyright © 2023 ABB. All rights reserved.